



POLYGON
EQUIPMENT
DATASHEET

HC-1125

Desiccant Dehumidifier



Product Description

The HC-1125 is a completely self-contained dehumidifier with an active Titanium Silica Gel desiccant wheel. The system is integrally designed and controlled for superior performance in even the highest humidity load conditions.

- Reactivation utility: electric with solid-state proportioning control. Optional direct fired gas with modulating gas valve for natural or propane gas.
- Dehumidifier housing: process and reactivation air flow insulation. Quiet operation with plenum mounted process fan.



Features

- Process air: flow rates of 600 to 1500 SCFM. Nominal moisture removal: 30 lb/hr at 75°F, 50% RH at 1125 SCFM. Delivered air moisture levels of -55°F dew point and lower are attainable
- Contact air seals: separate process and reactivation air pressures up to 8" water gauge with five-year life expectancy
- Process and reactivation fans: centrifugal, direct drive with totally enclosed fan-cooled motors
- Electrical controls: continuous automatic operation including motor starters, overload protective devices and full controls with indicating lights and fault circuits
- Desiccant reactivation via modulating electric, with propane or natural gas optional
- All wiring to NEC codes
- Drive system: simple drive-belt arrangement with few moving parts.

Benefits

- Weather-tight construction for indoor or outdoor use
- Low profile cassette design provides space savings
- Quick access for easy maintenance
- Modulating electric, gas: natural or propane
- Cost savings - 18" deep Titanium Silica Gel desiccant provides optimal drying performance with the least energy consumed
- Lightweight aluminum construction.



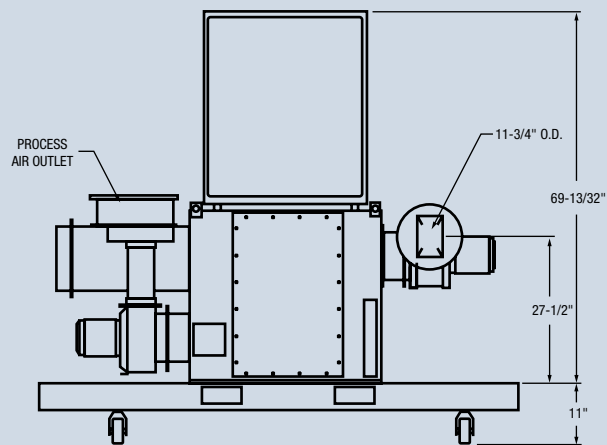
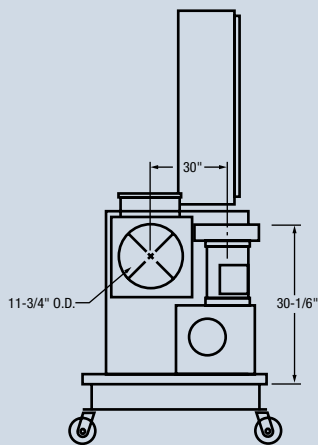
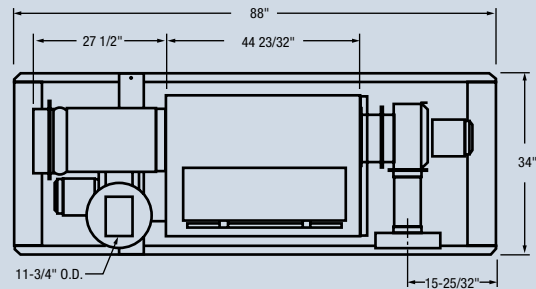

HC-1125

Equipment Specifications

- Length: 88"
- Width: 34"
- Height: 80"
- Weight: 560 lb
- Full Load Amps (FLA): 29 @ 460 volt three phase-electric reactivation
- Fuel required:
 - 2.1 g/hr diesel for electric
 - 1.5 g/hr diesel for gas or steam
 - 1-2 therms natural gas/hr
 - 1-2 gal/hr of propane
- Generator requirements:
 - 30 KW-minimum for electric
 - 20 KW-minimum for gas or steam
- SCFM range: 2.5" ESP @ 600-1500 SCFM
- NFPA 255-ASTM E84 compliant
- Insurance value: \$28,800.00

HoneyCombe® Wheel Technology

