

MOISTURE CONTROL SERVICES

MODEL DX-7-MCS



Munters Refrigerant based Dehumidifier unit offers:

ADVANTAGES

- Single package Air Conditioning, Dehumidification, Heating unit.
- Low operating costs with optimum reliability.
- Versatility of applications.
- Weather tight construction for indoor and outdoor use.
- Electric power can be run off of job site sources or portable generator.
- Low profile compact design, skid mounted for ease of transportation.
- Quick and easy access to all electrical and mechanical components for ease of maintenance.
- Light weight rugged construction

This unit provides outstanding Humidity control and cooling conditions using Refrigerant technology. It has the capability to remove large amounts of moisture from the air at high temperatures and humidities. These units are built and configured utilizing input from our customers and their project engineers. The Munters unit was made to perform up to rigorous standards in a variety of applications

FEATURES

- Process Airflow rates of up to 2800 cfm. Low temperature delivered air.
- High Capacity for volume of process air.
- Designed for outdoor use (NEMA 4).
- Single point electrical connection 460/3 phase Electric power with frame mounted fused disconnect.
- Electrical controls: Continuous automatic operation including motor starters, overload protective devices, full controls with indicating lights.
- Quiet operation with insulated panels to dampen noise.
- Periodic changing of filters only recommended maintenance on site.
- Side discharge/return for ease of application
- Energy efficient low amperage operation.



MODEL DX-7-MCS

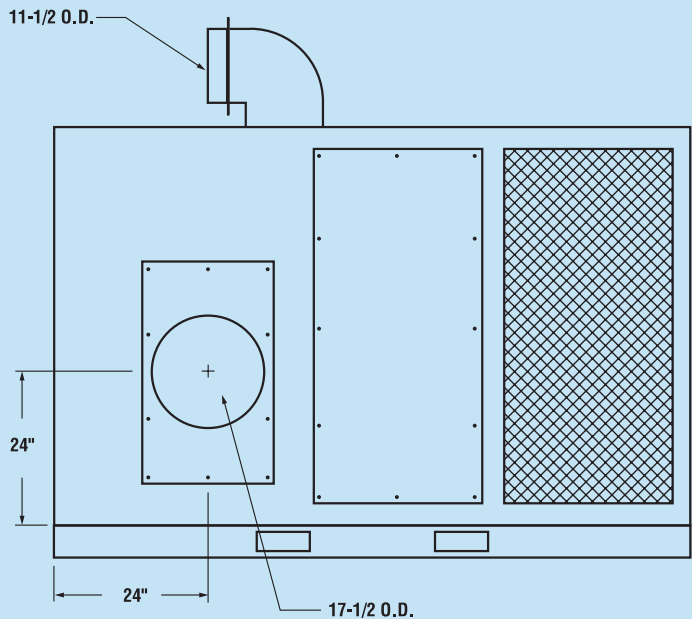
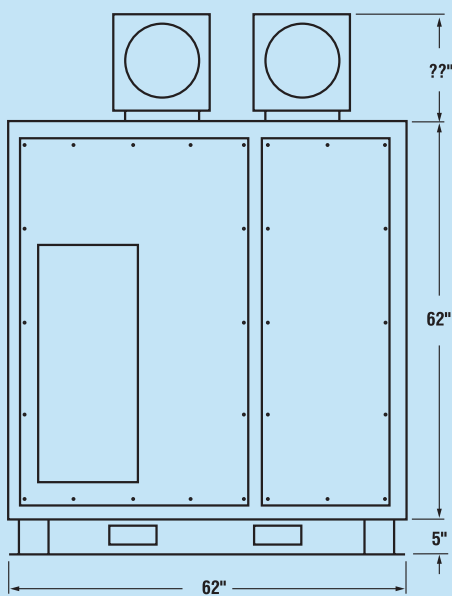
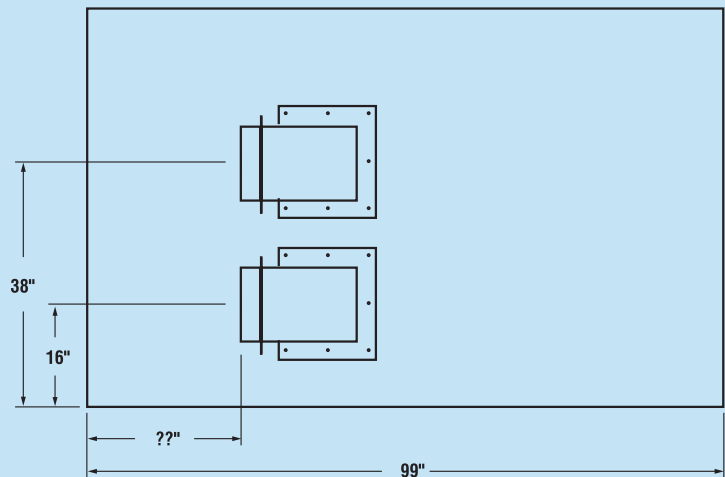

SPECIFICATIONS

- Maximum Dimensions:
99"L 62"W 74"H
- Maximum Weight:
2000#
- Power Requirements (w/heat):
60FLA/240 Volts
- Generator Required:
40KW Minimum
Fuel Required:
Diesel - 4 GL/hr
- Airflow:
1500-2800 cfm

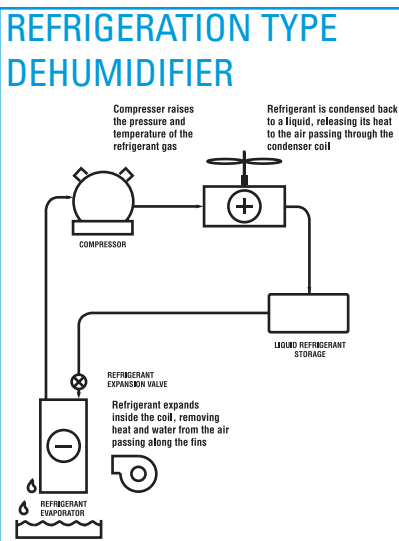

Moisture Control Services

Munters Corporation
Moisture Control Division

2008 Bloomingdale Road
Glendale Heights, IL 60139

Tel: 1-800 I CAN DRY

Fax: 1-630-351-7365

Web: www.muntersamerica.com

e-mail:

mcsinfo@muntersamerica.com

