

HG - 4



ADVANTAGES

Munters MCS model HG-4 indirect fired air heater delivers efficient, clean and dry heat for construction sites, industrial applications and temporary heating needs.

- Weather-tight construction for outdoor use
- Requires less than 1 AMP of 120 Volt power
- Quick access for easy maintenance.
- Modular design allows flexibility to be used in conjunction with dehumidifiers or high static blowers.
- Advanced electronic control system allows precise temperature control and eliminates broad swings during cycling.
- Provides abundant heat at a fraction of the cost of electric heaters with portable generators.
- Flexibility of exchange temperature and airflow allows peak performance and maximum output temperature.

FEATURES

- **Variable Process Air:** Will accept air flows from 3,850 - 9,000CFM.
- **Two Stage Controls:** For more controlled outlet temperature.
- **Thermostatically Controlled Outlet Temperature:** External thermostat is optional.
- **Efficient:** 72° F temperature rise at 4000CFM. High temperature limit 210°F
- **Mobility:** Durable steel frame and skid with fork pockets, lift rings and pins to allow multiple units to be stacked on site.
- **Indirect Fired:** Heat exchanger does not introduce combustion products or moisture into process airstream.
- **Dual Fuel:** Can be fired with natural gas or propane.

HG-4

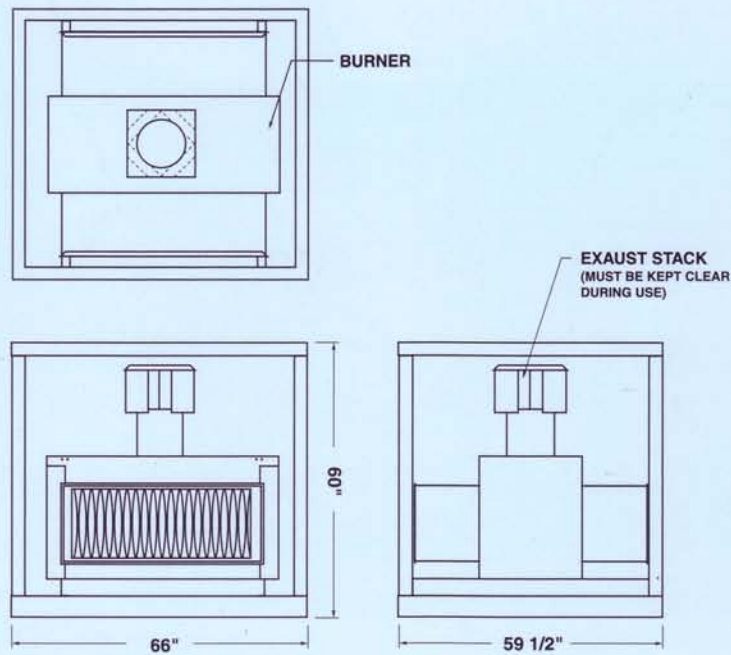

TYPICAL INSTALLATION

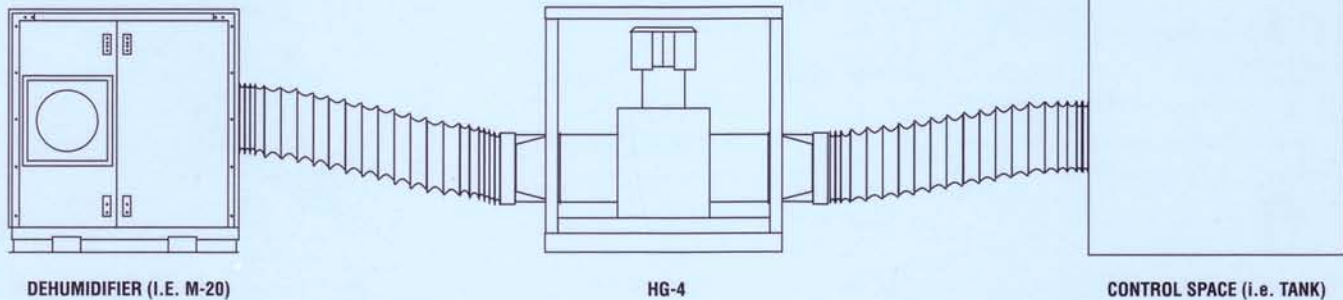

SPECIFICATIONS

- Heat Output:
312,000 btuh
- Dimensions in Transit:
66"L x 59.5"W x 60"H
- Dimensions in Use:
66"L x 96"W x 60"H
- Maximum Weight:
500#
- Power Requirements:
0.2 amps 120 volt FLA

- Fuel Required:
4.3 gals/hour propane
4 therms/hour natural gas
- Flexduct size:
18", inlet and outlet
- Gas Connection:
1/2" regulators will be included with each heater
- Skids:
Carbon steel with fork pockets, lifting eyes (stackable)
- CFM Range:
3850-9000



Munters Corporation
79 Monroe Street, P.O. Box 640
Amesbury, MA 01913-0640
TEL: (978) 388-4900 or (800) I-CAN-DRY
FAX: (978) 241-1215
WWW: <http://www.muntersamerica.com>
E-mail: info@muntersamerica.com