



**POLYGON  
EQUIPMENT  
DATASHEET**

# 64 KW Heater

## Direct Heating System



### Product Description

The Polygon 64 KW electric heater provides clean, dry electric heat for use with auxiliary equipment or as a stand-alone heat source. It features clean and efficient open heating elements, weatherproof enclosures (for safe use outdoors) and simple controls.

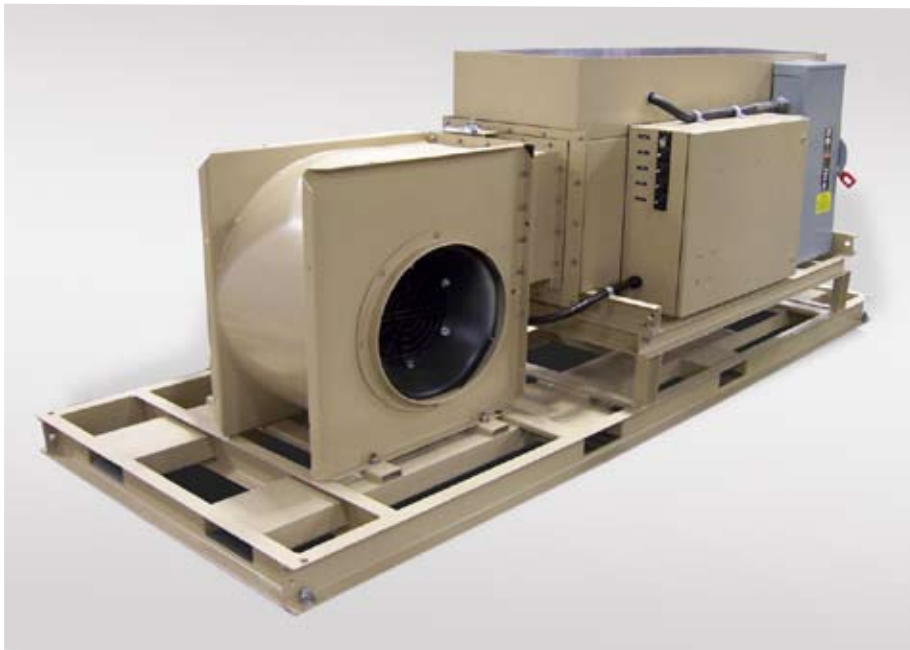

### 64 KW Heater Product Information

- Integrated: combined heater and blower for single-point power and duct connection
- Air mixing: allows a wide variety of air flow combinations with fresh, return, or dehumidified air to provide precise and efficient climate control
- Clean heat: electric elements produce no by-products and convert 100% of the supplied electric power without adding moisture

### Features

- Backward inclined fan delivers 4,500 SCFM of airflow at 6" of static pressure capable of long duct runs
- Welded skid with casters and forklift pockets
- Completely self-contained design
- 45°F temperature rise @ 4,500 SCFM
- High temperature limit of 120°F
- NEMA rated control panel with integral heater control

### Benefits

- Improved workspace environment
- Reliable operation using existing facility services for power
- Control temperature and relative humidity by delivering air directly where it is needed
- Fast and simple operation and field service
- Safe and easy control of outlet temperature
- Quick access for easy maintenance





# 64 KW Heater Direct Heating System

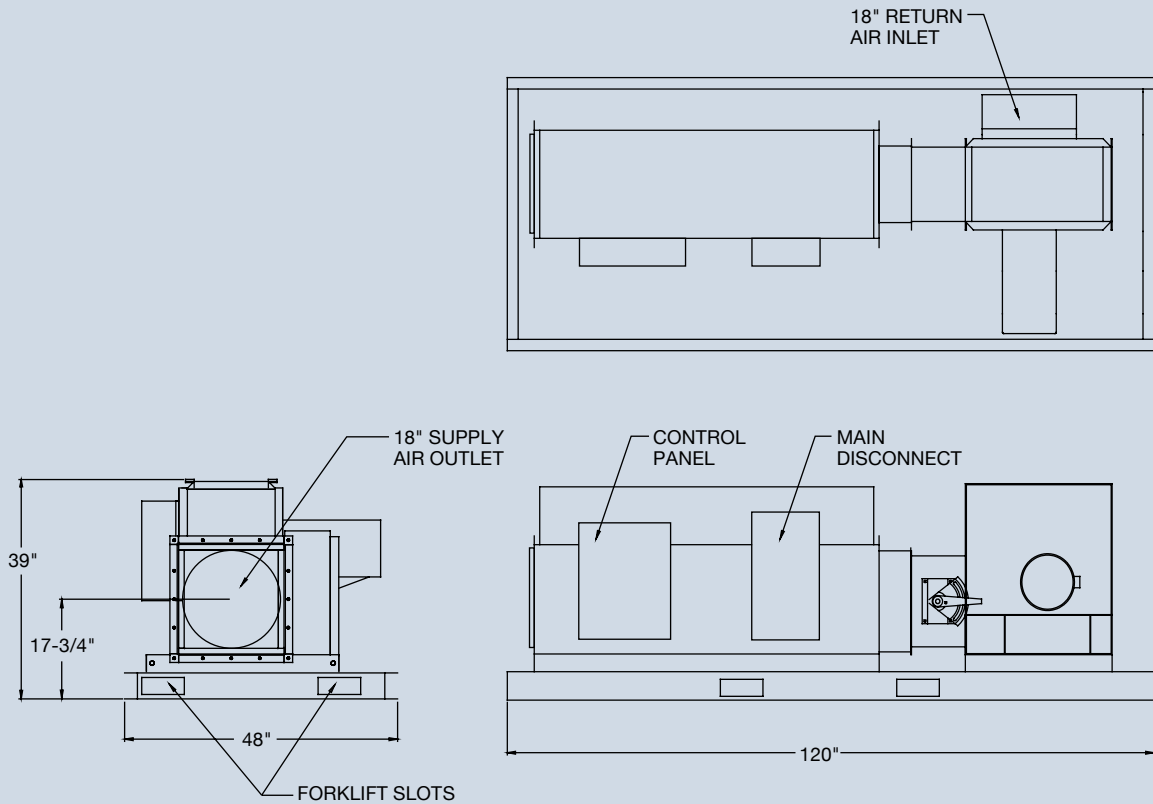

## 64 KW Heater

### Equipment Specifications

Rating: 218,500 BTU/HR @ 4,500 SCFM  
Length: 120"  
Width: 48"  
Height: 39"  
Weight: 1,000 lb  
Full Load Amps (FLA): 100 @ 460 volt three phase  
Air outlet: 24" diameter  
Air inlet: 18" diameter  
Air flow: 4,500 SCFM  
Insurance value: \$14,500.00